

**FIXED DESIGN
ONE CONTRACT
PAY ON COMPLETION!**



ARTIST IMPRESSION ONLY. HAMPTON FACADE FOR ILLUSTRATIVE PURPOSES. PLEASE REFER TO PLANS FOR ACTUAL ELEVATION.

CUSTOM 28.9 SIDE ACCESS

LAND SIZE: 438.2m² | HOUSE SIZE: 268.69m² | SQUARES: 28.9Sq

\$1,139,900 HAMPTON (MODIFIED TO SUIT SIDE ACCESS) FACADE INCLUDED

LOT 1 CNR WARNERVALE ROAD & MCGEACHIE DRIVE - HAMLYN TERRACE

INCLUSIONS:

- ✓ 5 Bedrooms with Double Locked-up Garage
- ✓ Tiling to Verandah, Entry, Kitchen, Dining, Family & Alfresco
- ✓ Carpet to Lounge, Stairs, Sitting & Bedrooms
- ✓ Natural gas package incl. Instantaneous HWS
- ✓ Fixed Site Costs & Basix Requirements
- ✓ Insulation to Ceiling & Walls (Except Garage)
- ✓ 2.59m Ceilings (Ground Floor Only)
- ✓ T2 Termite Treated Frame
- ✓ Perimeter Termite Protection
- ✓ Coloured concrete Driveway & Pathway to Porch
- ✓ Remote Control Panel Lift Garage Door
- ✓ Stone benchtop to Kitchen
- ✓ 900mm Westinghouse Appliances
- ✓ Alarm System
- ✓ 10 LED Downlights
- ✓ Fully Ducted Day/Night Air Conditioning
- ✓ **25 Years Premium Upgrades***

UPGRADES PLUS

- ✓ Gloss Two-tone Kitchen Cupboards
- ✓ Finger Pull to Overhead Kitchen Cupboards
- ✓ Front Door Upgrade
- ✓ Accent Internal Panel Doors
- ✓ Gloss Vanities
- ✓ Full Height Wall Tiling to Bathroom & Ensuite
- ✓ Selected Glazed Porcelain Tiles to the Main floor
- ✓ Water Point fridge Space
- ✓ Gas Point to Alfresco
- ✓ Fly screens to all openable windows

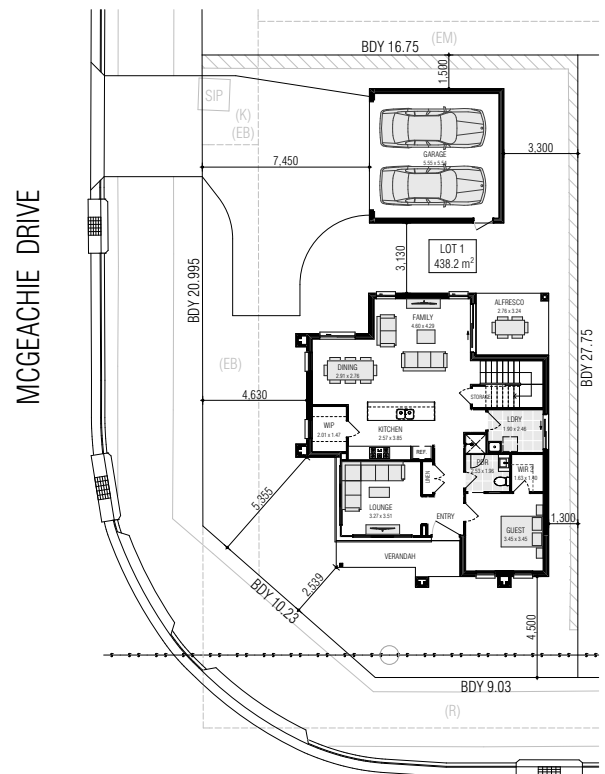

WARNERVALE ROAD

- (K) EASEMENT TO DRAIN WATER 2.5 WIDE (DP 1287400)
- (EB) EASEMENT TO DRAIN WATER 2.5 WIDE (DP 1048284)
- (EM) EASEMENT TO DRAIN WATER 1.5 WIDE (DP 1048284)
- (R) ROAD WIDENING



CLIENT INITIALS.....

25 YEARS

PREMIUM UPGRADES

UP TO \$51,650 IN VALUE*

*Offer provides for the "Living Inclusions" as listed to all Contract Homes. The "25 Years Premium Upgrades" are only available for home designs listed on the current Firststyle Homes Price List. This offer is subject to the client entering into a Building agreement within the specified period stated in their Firststyle Homes Quotation. Offer applies to single dwelling, contract homes to standard Firststyle design. Items shown are indicative only and are not redeemable for cash or alternative items and may be subject to amendment without notice at the discretion of the builder. This offer is not available in conjunction with any other offer and is only available to clients requesting a Quotation from 1 December 2022. B.L.113412C

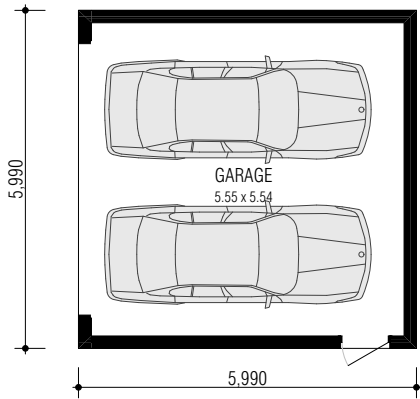

Actual Elevation of home designed to suit

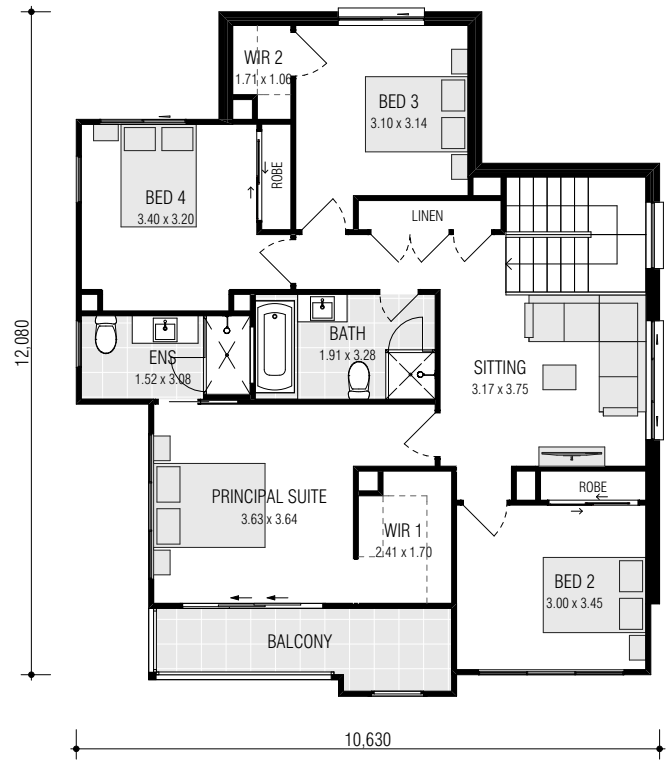
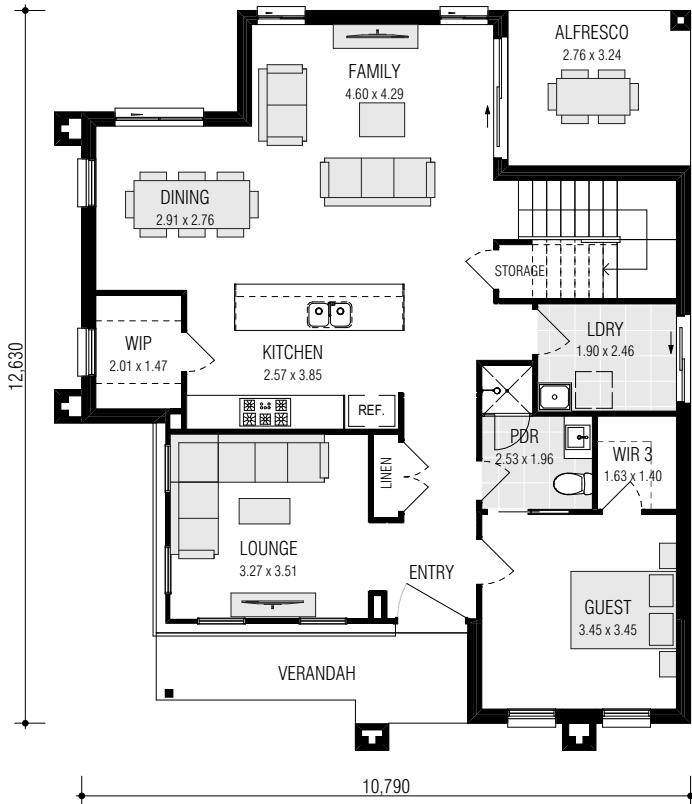

CUSTOM 28.9

FRONTAGE REQUIRED (MINIMUM): 12.65m
HOUSE SIZE: 268.69 m²
SQUARES: 28.9sq
DATE: 4/07/2023

DISCLAIMER: All plans, images and areas are indicative only. The finishes to the nominated design are to be used as a guide only. Purchases are advised to refer to the Land Contract and/or Builders Tender and Contract for precise dimensions, specifications and inclusions. Firststyle Homes reserves the right to change specifications, materials and suppliers without notice. B.L 113412C

Gross Areas	
Ground Floor	107.36
First Floor	100.98
Garage	35.88
Alfresco	8.94
Porch	7.67
Balcony	7.86
Totals	268.69 m ²

CLIENT INITIALS.....